

A MAYAN ASTROLOGY PRIMER

By Kenneth Johnson

Most people seem to think that “Mayan astrology” consists simply of your day sign and number. In reality, the art is much more complex.

First things first. The day sign is more important than the number. People always say, “I was born on Tz’i (Oc),” or, “My *nawal* (*nagual*) is Imox (Imix),” but they often don’t mention the number. I know that my teacher in the healing arts was born on a Kej (Manik) day and my teacher in the K’iche’ language was born on a Kawoq (Cauac) day, but after several years of close contact I still don’t know what their birth number is. I have been sitting next to the Daykeeper Dona Reina and helping her to prepare the offerings for countless ceremonies over the years, but all I know is that she was born on B’atz’ (Chuen). I still don’t know the number.

Sometimes they talk about day signs in the same way that Westerners talk about sun signs. Overheard in the kitchen: “Rafael really likes Angelina.” “Of course he does! She was born on Aq’ab’al (Akbal), and you know what romantics *they* are!” “Yes, but he was born on Kan (Chicchan), and they’re so secretive that he will never tell her how he feels about her.”

Yes, it really is like that. I know it sounds bizarre to imagine going to a club and trying to meet someone by saying, “Hi there, what’s your *nawal*?” But by Western standards there are a lot of customs down there which take a bit of getting used to.

Numbers modify day signs. The quality of the number helps to shape the way in which the day sign will manifest itself in the world, but the day sign is your quintessential archetype.

And we have more than just one day sign. The most basic form of a Mayan horoscope is the so-called Mayan Cross. Beginning with your day sign and its number, count backwards a certain number of signs and you will reach what is called one’s Conception sign. Count forward the same number of signs from your birth sign and you will reach what is sometimes known as your Future sign, though I seldom heard anyone use that term. They usually said “*destino*,” your Destiny sign.

Someone who is deeply schooled in the tradition may tell you, “My *nawal* is 6 B’atz’, my conception sign is 11 Aq’ab’al, and my destiny sign is 1 Kawoq.” This is pretty much the same thing as when someone says: “My Sun is in Taurus, my Moon in Aries, and Sagittarius is rising.”

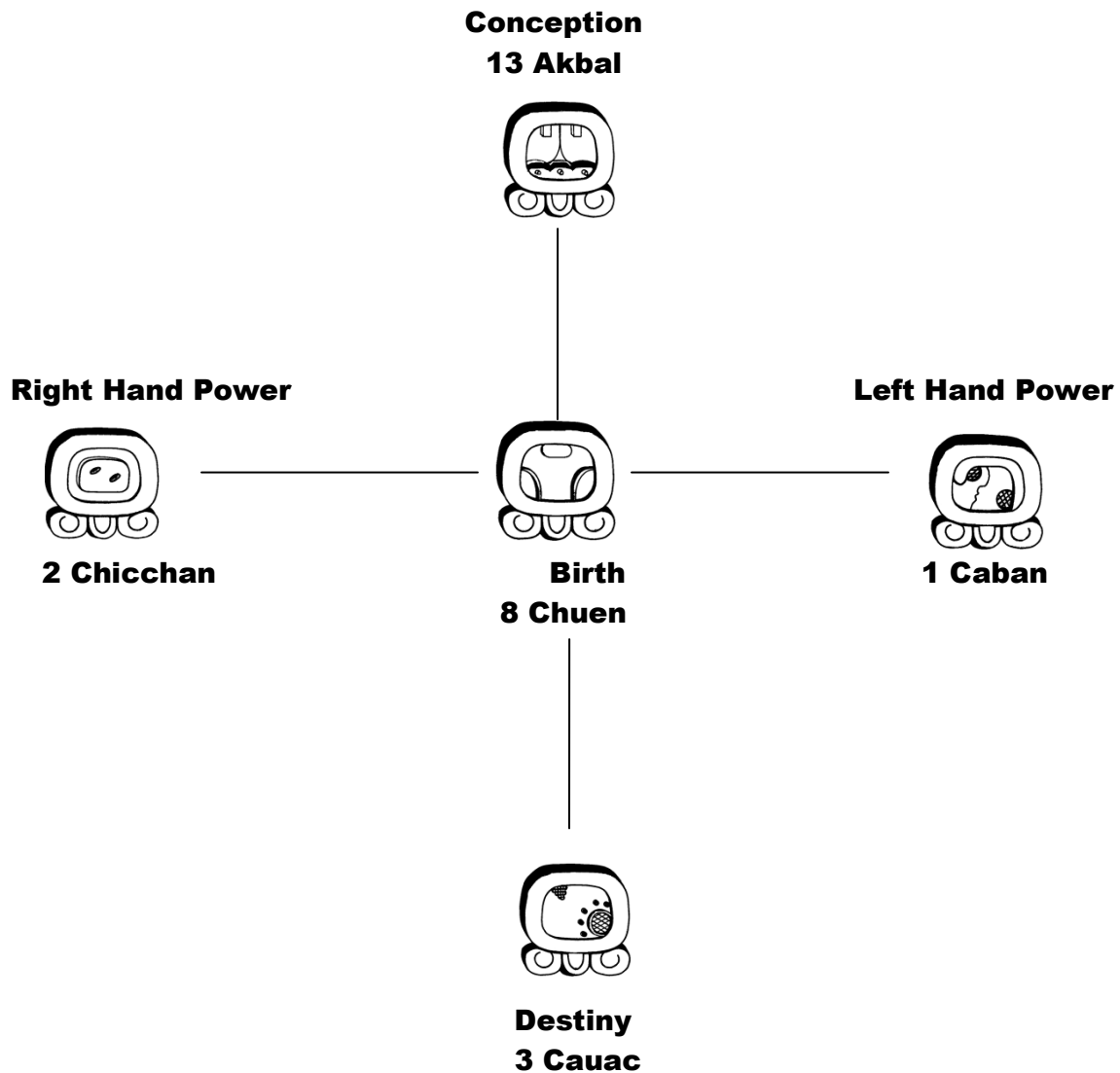

These three signs form a central vertical column and are the most important signs in your chart. But you can start with the birth sign again, counting a certain number forward and backwards, placing these new signs to the left and right of your birth sign respectively to create a cross, and this will form your Left Hand Power or feminine side, and your Right Hand Power or masculine side. This is your own personal “cross of the four directions,” your own personal Medicine Wheel.

Even so, one can extend this basic Mayan Cross into a more complex nine-sign horoscope. Count an equal number of signs from the Conception and Future signs and place them on the right and left of those signs as well. Now you have three columns, one on the right, one on the left, and that all-important central column in the middle.

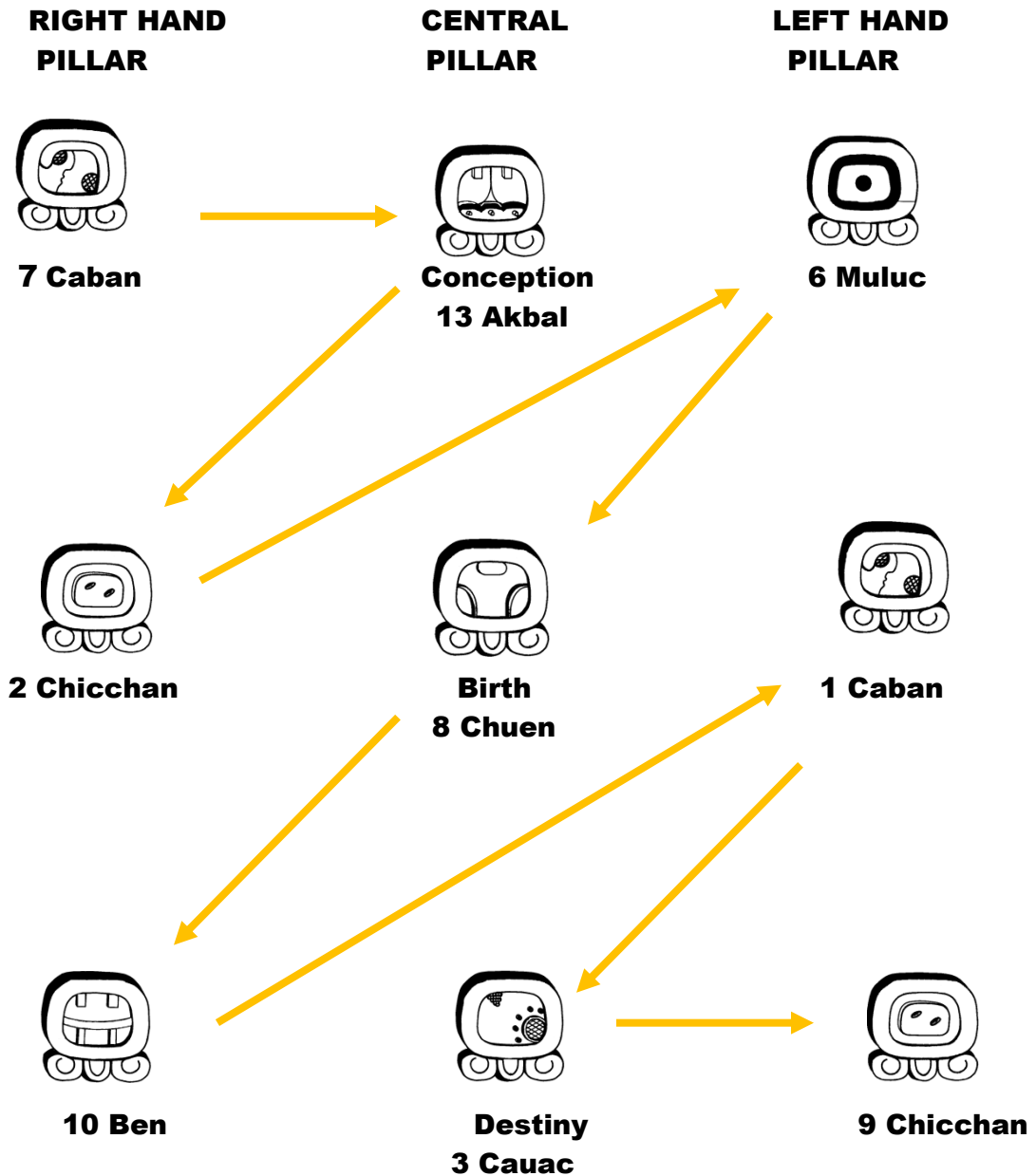

But even that is not the full extent of it. Everyone born on a particular day will have the same formation, so this gives us only 260 combinations – not quite enough to understand the full measure of a complex human being. We need to pay attention to the Year Lord as well. The Year Lord adds diversity to the mix. In Momostenango the Year Lord was always described to me as a guiding factor in our outward or public persona, whereas the *nawal* (*nagual*) or birth sign is our inner archetype.

Beyond that, we can go even farther. If one can determine the phase of the moon under which you were born, we will know how bright the moon was. From this we may ascertain how strong your intuitive or feminine side is. Similarly, if we know the exact time of birth, we may also ascertain how bright the sun was, which helps us understand how strong your masculine or logical side is.

By now, some of you will be asking, “What about the *trecena*?” And it may come as something of a shock when I say that the Maya seldom if ever use it as an astrological factor. In all my years of study in Guatemala, I have never encountered a single teacher who made use of it.

This is not to say that it has no place in the history of Sacred Calendar astrology. An Aztec document called the Codex Borbonicus is believed to have originated in Colhuacan, where the ancient Toltec knowledge survived longer than elsewhere. In this codex, it becomes clear that the *trecena* was a major, perhaps controlling, factor. But it is not so among most of the contemporary Maya.

Finally, it should be said that Mayan astrology is by no means fatalistic. The horoscope is a tool to help you better understand how your own personal rhythms relate to the cosmic rhythm of the *ch'ol q'ij* (*tzolk'in*). If we follow the sequence of all nine signs in your chart as they occur in the calendar, it will become clear that what we have is 29 days – a lunar month. This is sometimes called “your personal lunar month.” Its pattern forms a lightning bolt that runs through your whole chart, and this is often referred to as “the Path of Feathered Serpent.” Some esoterically minded individuals meditate and perform ceremony on each of the nine days of their personal lunar month whenever it recurs. This is said to awaken the “inner lightning” within the human body.

Thus the horoscope becomes a shamanic tool to awaken the powers within us.